

GURLEY MODELS LA18, LA20, LA25, AND LA35 **ABSOLUTE** LINEAR ENCODERS

MOTION TYPE:

LINEAR

USAGE GRADE:

INDUSTRIAL

OUTPUT:

ABSOLUTE

MAX RESOLUTION:

0.5 TO 4μm

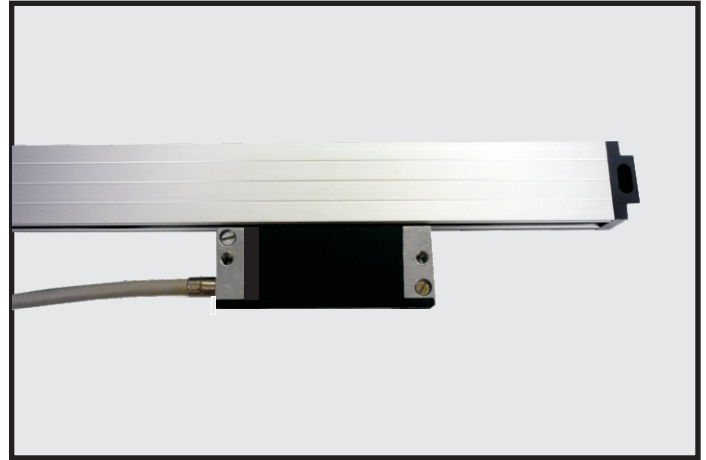

HIGH RESOLUTION - INDUSTRIAL RUGGEDNESS

The Models **LA18**, **LA20**, **LA25** and **LA35** are optical absolute linear encoders designed for long life in medium to high-performance applications. The compact **LA18** offers measuring lengths up to 1.2 m (48"); the almost-as-compact **LA20** measures up to 1.5 m (60"); and the more robust **LA25** and **LA35** have a maximum measuring length of 2.0 m (80"). All models have a reliable internal ASIC to provide resolution as fine as 0.5μm in SSI format. The output protocol is RS422 / binary SSI based on SP490.

Precision ball bearings allow the reading head to traverse the glass scale at speeds up to 1 m/s (40 in/s). The system is protected to IP53 by an aluminum extrusion and rubber sealing flaps. The encoder has a unique virtual absolute scale but there is no necessity to have an initialization movement thus it generates a true absolute position, which is available immediately after applying the power supply.

Each output code represents only one measuring position.

ingenuity[®]@work

ISO
9001
CERTIFIED

Gurley Precision Instruments
514 Fulton Street
Troy, NY 12180 U.S.A.
(800) 759-1844, (518) 272-6300, fax (518) 274-0336,
Online at www.gurley.com, e-mail: info@gurley.com



SPECIFICATIONS

	See note	LA18	LA20	LA25	LA35
Cross-section, mm (in)		18 x 63 (0.71 x 2.48)	20 x 68 (0.79 x 2.68)	25 x 69 (0.98 x 2.72)	35 x 79 (1.38 x 3.11)
Measuring length ML, mm (in)		70-1240 (3-48)	70-1540 (3-60)	70-1940 (3-80)	1140-2040 (45-80)
Overall length, mm (in)		ML + 114 (ML + 4.5)			
Weight, kg (lb)		0.12 + 0.7/m (0.28 +0.03/in)	0.12 + 1.1/m (0.28 +0.05/in)	0.12 + 1.6/m (0.28 + .09/in)	0.12 + 3.3/m (0.28 + 0.11/in)
Resolution, μm		0.5, 1, 2, 4 OR 8 μm			
Accuracy (at 20°C)		Grade A: $\pm 3 \mu\text{m/m}$ ($\approx \pm 36 \mu\text{in/ft}$) Grade B: $\pm 5 \mu\text{m/m}$ ($\approx \pm 60 \mu\text{in/ft}$)			
Hysteresis		0.5 μm (20 μin)			
Input power		5V \pm 0.25V @ 350 mA max			
Output Device (OD=RS)		SP490 on all channels (RS-422)			
Max speed		1 m/s (40 in/s) at 0.5 micron			
Max acceleration		30 m/s ² (1200 in/s ²)			
Driving force		1.5 N (6 oz)			
Operating temperature		0° to 50°C (32° to 122°F)			
Sealing		IP53			

NOTES:

1. Output signals: binary 24 bit max with resolution of 0.5 μm on 2 m of length

As part of our continuing product improvement program, all specifications are subject to change without notice.



SPECIFICATIONS

INPUT POWER

+5 VDC ± 0.25 V @ 350 mA max.

OUTPUT FORMAT

SSI (Binary Code)

The current value of the position is being transferred bit by bit along the DATA line starting from MSB and is synchronized by signal CLOCK generated at the receiver end.

In starting mode lines CLOCK and DATA are in LOG 1 state. The transmission cycle begins with the first falling edge of the CLOCK, it means that by that time the current position is being maintained and the value is transmitted into line DATA by positive edges of CLOCK.

After the transfer of all bits line DATA remains low (LOG 0) for a period of time T₃.

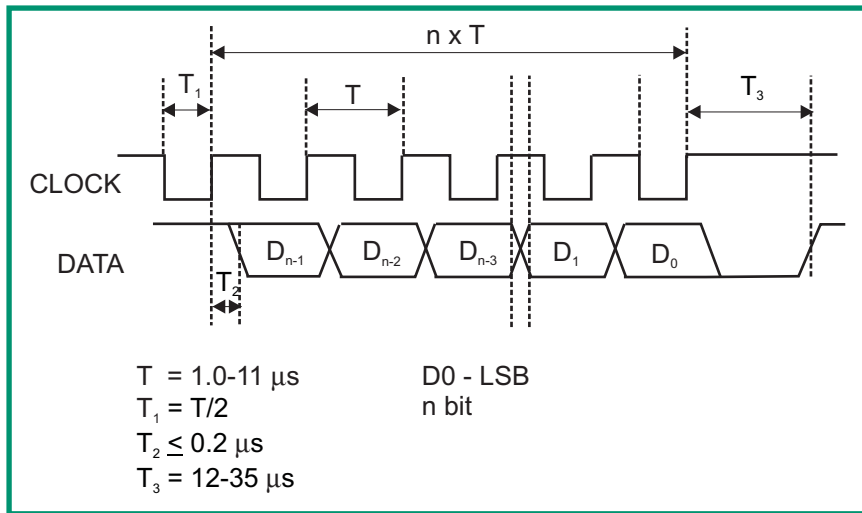

PINOUTS (DE-9P)

Electrical Signal	Pin	Color
Case	1	Shield/Drain
Clock	2	Yellow
/ Clock	3	Brown
Data	6	Green
/ Data	7	Orange
0V	9	Black
+5V	5	Red

READ HEAD OUTLINE DRAWING

Encoders LA18/20/25/35 have two main parts: scale installed into an aluminum extrusion and a moving read head along the scale and partially inside of the extrusion.

The read head consists of a scanning carriage (moves inside of the extrusion along the scale) and a mounting outside part of the read head, which supports the electronics circuit board, cable exit and has mounting holes for installation.

The glass scale is installed in the aluminum body and is being held by means of a rubber cylindrical flexible strip. The scale by itself has a two chrome-on-glass patterned tracks: incremental and virtual absolute (pseudorandom).

The scanning carriage of the read head while moving detects the modulation of light defining each time the current code of the true absolute position of the read head, which is available immediately after applying the power supply. Hence, there is no necessity for an additional initialization movement.

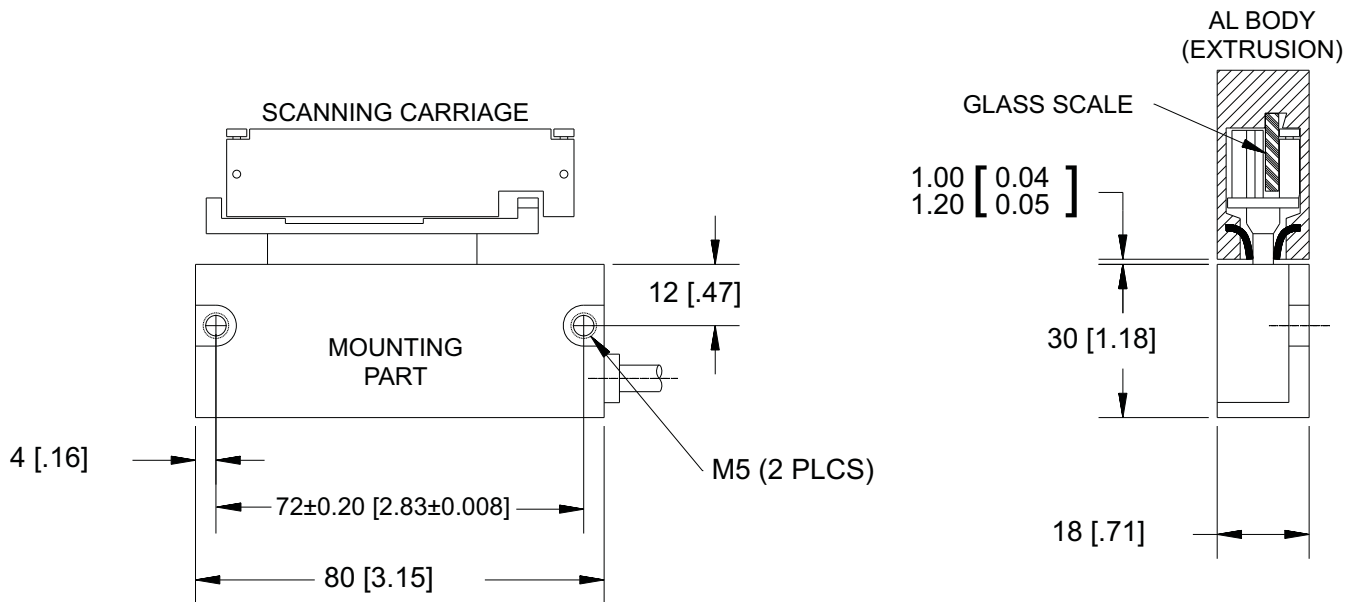

Notes for linear absolute encoder installation

The encoder should be installed as close as possible to the line of measurement (in measuring equipment) or to the line of cutting (in machine tools).

It is recommended that:

1. The body of the encoder be mounted to the moving part of the object and the read head to the stationary part, which allows the cable to be fixed easier.
2. The cable to be protected from contamination, metal chips and coolant.
3. The encoder be closed with a special cover and put with the Read Head opposite to the zone of cutting (in case of machine tools).
4. The gap "A" to be defined by a special shim included with the encoder. Gap deviation depends on the measuring length and is around 0.2 mm for lengths 1 m; 0.02 mm for lengths of 100 mm.

MODEL LA18 LINEAR ENCODERS

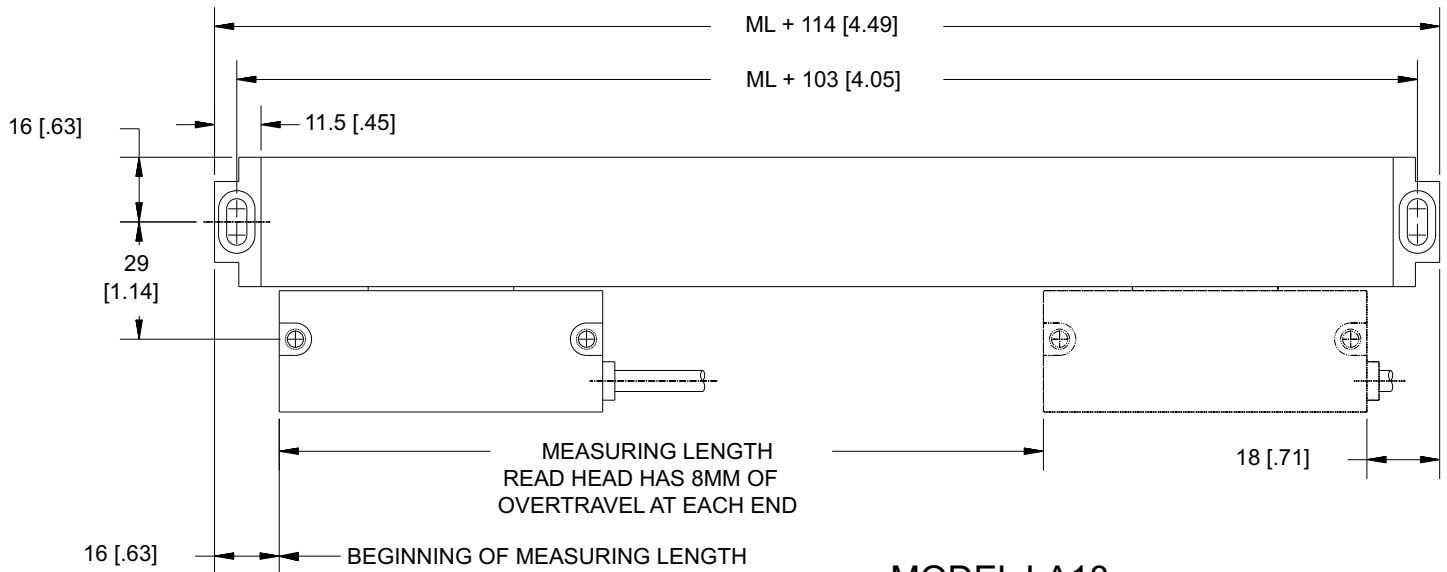

MODEL LA18
M = MACHINE GUIDES

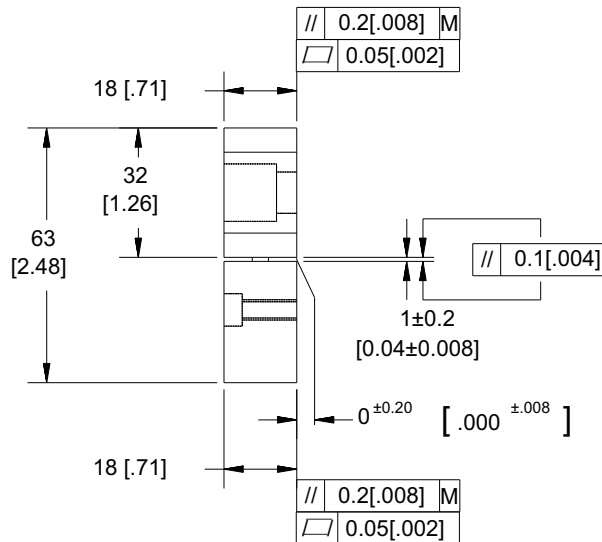

MODEL LA20 LINEAR ENCODER

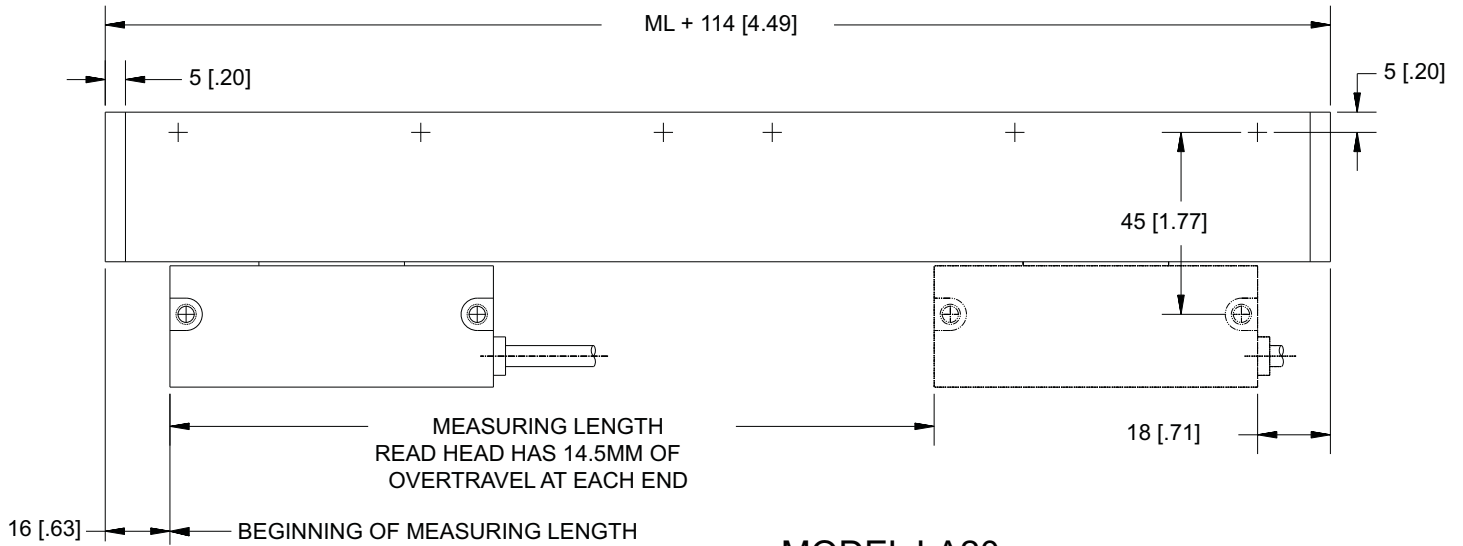

MODEL LA20

M = MACHINE GUIDES

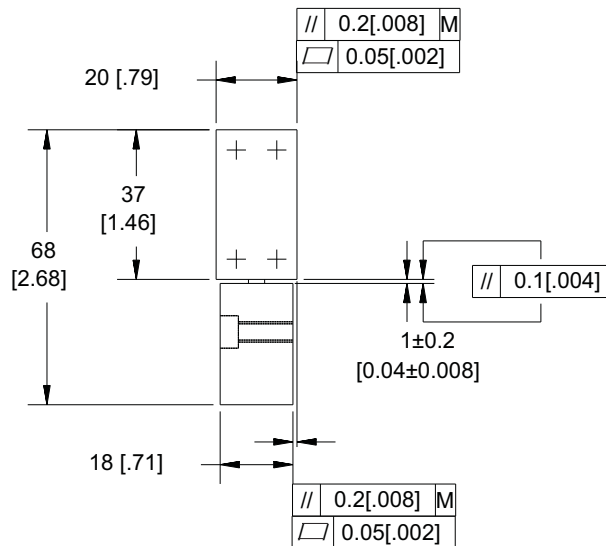

LAXX

PAGE 6 OF 10

0410

Gurley Precision Instruments
514 Fulton Street
Troy, NY 12180 U.S.A.
(800) 759-1844, (518) 272-6300, fax (518) 274-0336,
Online at www.gurley.com, e-mail: info@gurley.com



MODEL LA25 LINEAR ENCODER

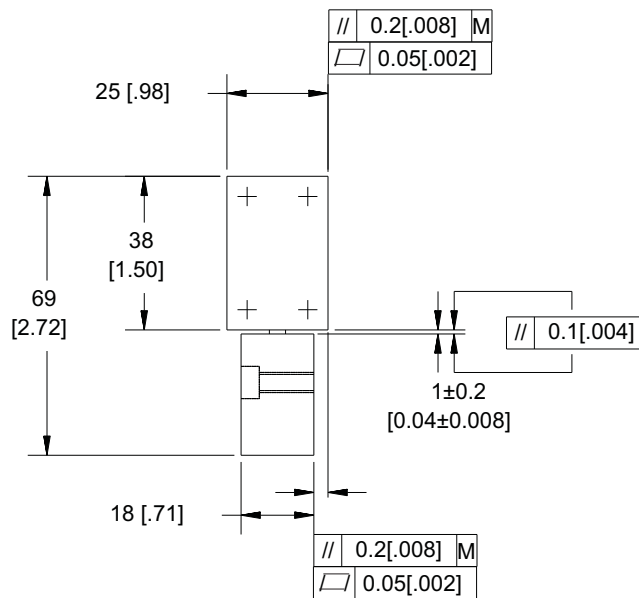
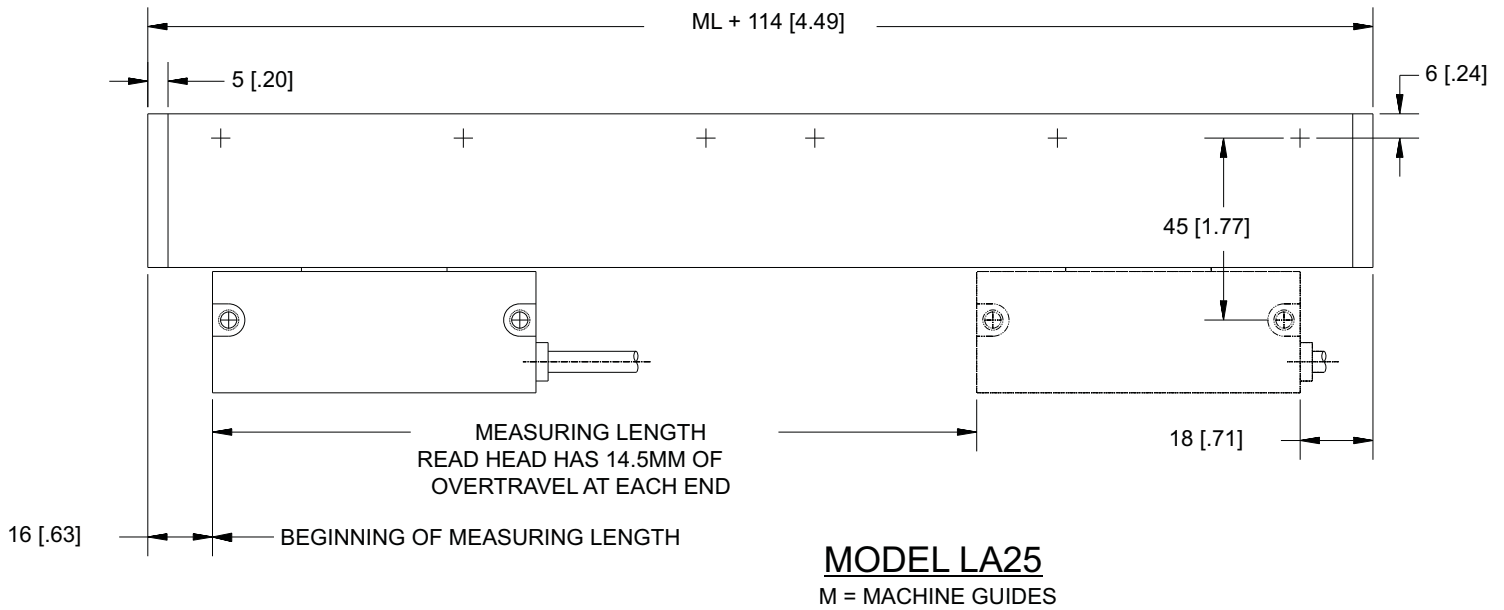

MODEL LA35 LINEAR ENCODER

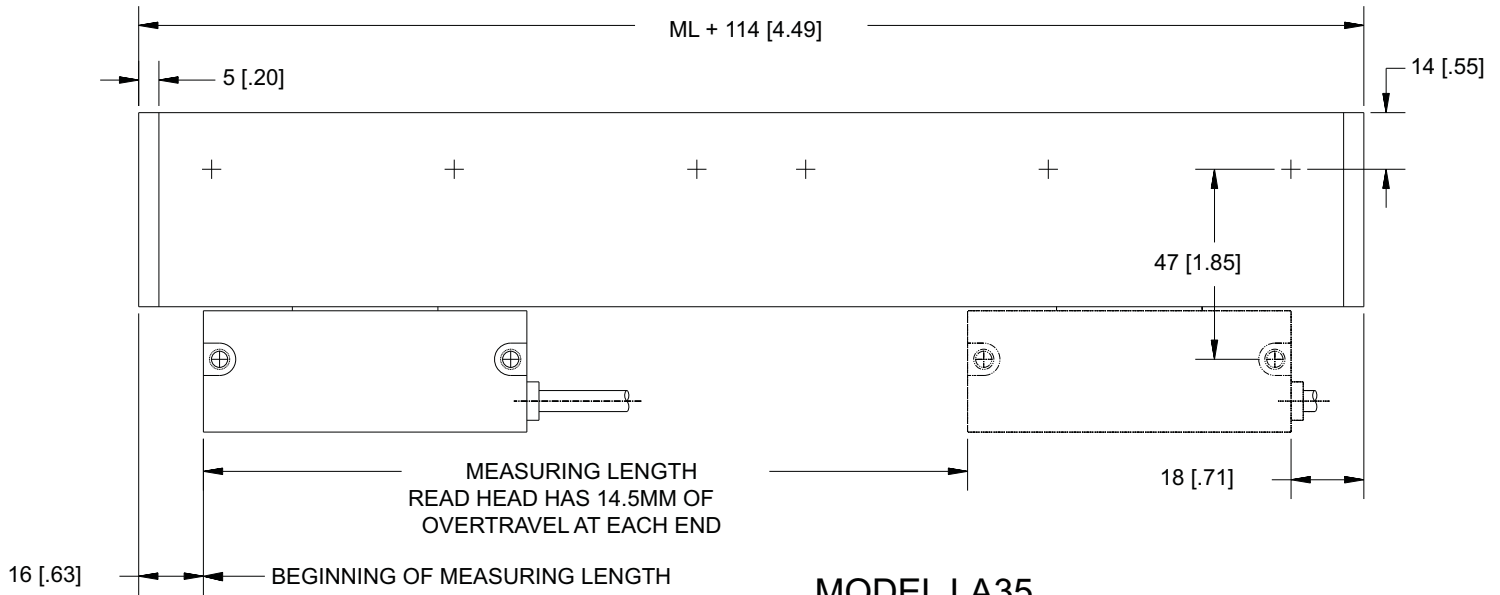

MODEL LA35

M = MACHINE GUIDES

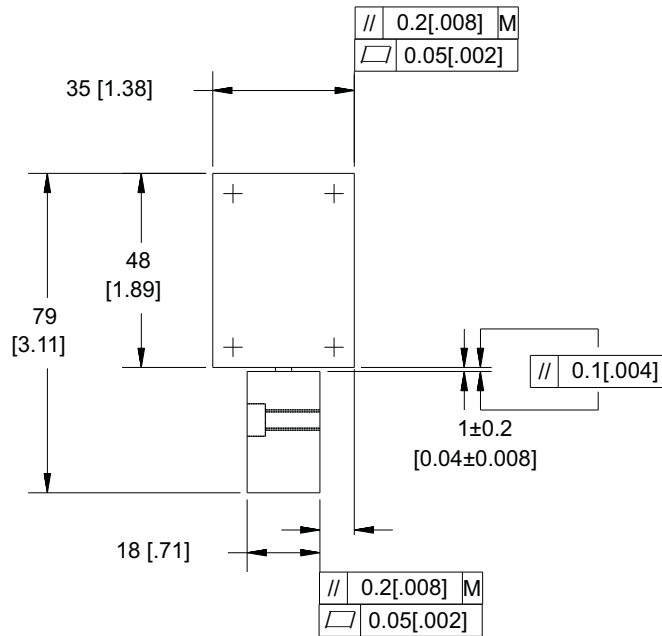

LAXX

PAGE 8 OF 10

0410

Gurley Precision Instruments

514 Fulton Street

Troy, NY 12180 U.S.A.

(800) 759-1844, (518) 272-6300, fax (518) 274-0336,

Online at www.gurley.com, e-mail: info@gurley.com



MOUNTING HOLES FOR LA20, LA25, AND LA35

MOUNTING HOLES FOR LA20, LA25 AND LA35

FIGURE 1
70 ≤ ML ≤ 570

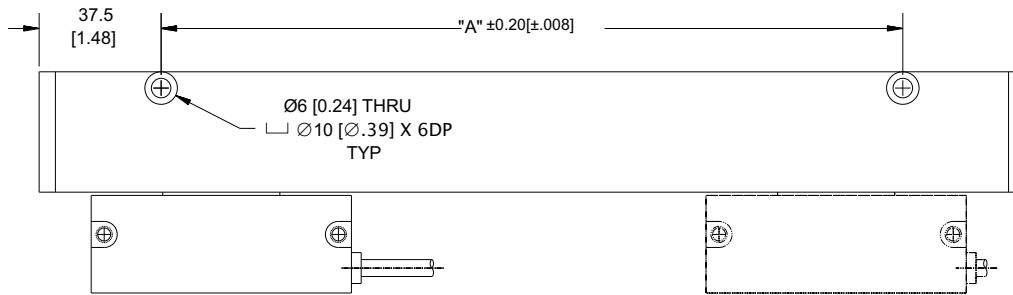

ML	A
70	100
120	150
170	200
220	250
270	300
320	350
370	400
420	450
470	500
520	550
570	600

FIGURE 2
620 ≤ ML ≤ 1020

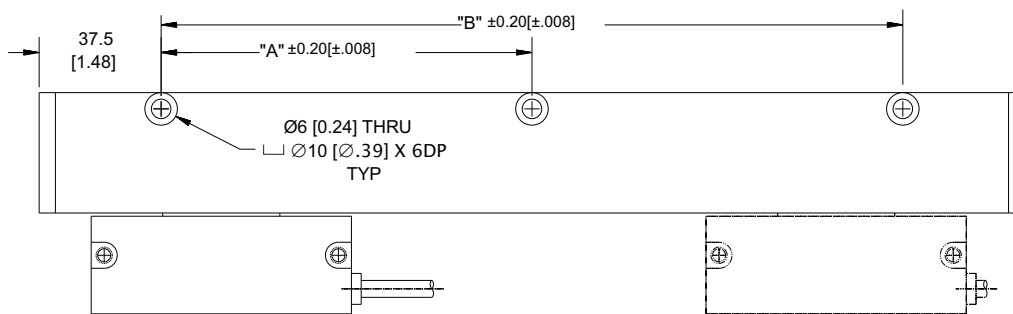

ML	A	B
620	350	650
720	400	750
820	450	850
920	500	950
1020	550	1050

FIGURE 3
1140 ≤ ML ≤ 3220

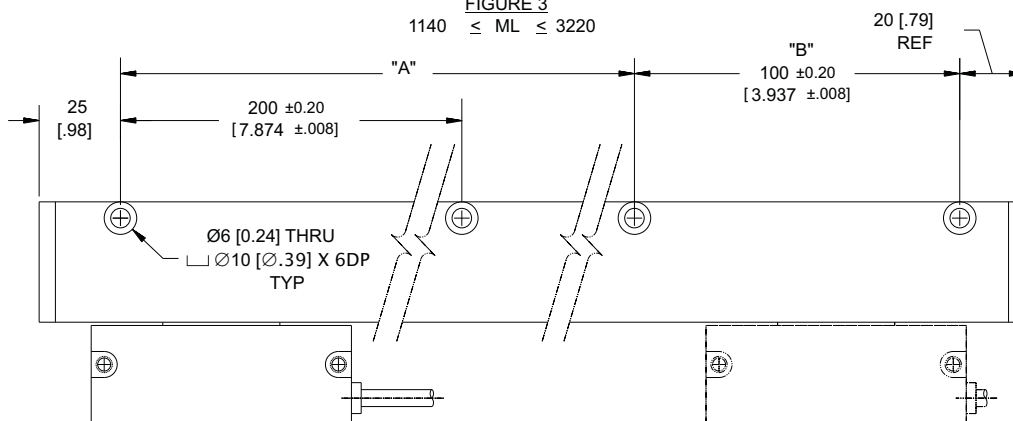

ML	NO. OF HOLES	A	B
		# SPACES @ 200MM	# SPACES @ 100MM
1140	7	6	0
1240	8	6	1
1340	8	7	0
1440	9	7	1
1540	9	8	0
1640	10	8	1
1740	10	9	0
1840	11	9	1
1940	11	10	0

ORDERING INFORMATION

MODEL	RES	ACC	IN	OUT	ML	EXIT	TYPE	CABLE	CONN	SPEC

MODEL

LA18 18 x 63 μm **cross-section**
LA25 25 x 68 μm
LA20 20 x 69 μm
LA35 35 x 79 μm

EXIT -

A Cable exits to the right

TYPE - Of Cable

S Shielded

RES - Resolution

005 0.5 μm (\approx 20 μin)
010 1 μm (\approx 40 μin)
020 2 μm (\approx 80 μin)
040 4 μm (\approx 160 μin)
080 8 μm (\approx 320 μin)

CABLE - xxx Cable length, inches

060 Standard for $ML \leq 570$
120 Standard for $570 < ML \leq 1240$
180 Standard for $1240 < ML \leq 2040$
240 Standard for $2040 < ML$

ACC - Accuracy

A $\pm 3 \mu\text{m/m}$
B $\pm 5 \mu\text{m/m}$

CONN

P Pigtails (no connector)
S DE-9P

IN - Input voltage

5 +5Vdc

SPEC - Special Code

Issued at the time of order to cover special customer requirements
N No special features

OUT - Output format

S SSI, Binary, RS 422

ACCESSORIES (order separately)

M06 Mating connector for DE-9P

ML - Measuring Length*

xxxx mm

* maximum lengths

LA18 1240mm
 LA20 1540mm
 LA25 1940mm
 LA35 2040mm

SPECIAL CAPABILITIES

For special situations, we can optimize catalog encoders to provide higher frequency response, greater accuracy, wider temperature range, reduced torque, non-standard line counts, or other modified characteristics. In addition, we regularly design and manufacture custom encoders for user-specific requirements. These range from high-volume, low-cost, limited-performance commercial applications to encoders for military, aerospace and similar high-performance, high-reliability conditions. We would welcome the opportunity to help you with your encoder needs.

WARRANTY

Gurley Precision Instruments offers a limited warranty against defects in material and workmanship for a period of one year from the date of shipment.



Gurley Precision Instruments
 514 Fulton Street
 Troy, NY 12180 U.S.A.
 (800) 759-1844, (518) 272-6300, fax (518) 274-0336,
 Online at www.gurley.com, e-mail: info@gurley.com

